

MAINTENANCE MANUAL

FOR HALOCARBON GAS SYSTEM

HFC 227ea - HFC 125 - HFC23



BETTATI ANTINCENDIO s.r.l.

Via Disraeli, 8 - 42124 RE Tel. +39 0522 / 369711 (R.A.) - fax +39 0522 / 791052

E-mail: info@bettatiantincendio.it

P.IVA 01979170352 C.F. 01979170352



Contents

1	INTRODUCTION	4
1.1	Scope and purpose of manual	4
1.2	Standards and Code of practice	4
1.3	Terms and definitions	5
1.4	Service schedule	6
1.5	Periodicity service schedule	6
1.6	System components	8
2	SYSTEM SURVEILLANCE.....	12
3	SYSTEM CONTROL.....	16
3.1	Essential operations for the extinguishment system control	19
3.1.1	Minimum tools for maintenance	19
3.1.2	Enclosure every 12 months.....	19
3.1.3	Pipeline and nozzles.....	19
3.1.4	Cylinder bank	20
3.1.5	Operating instruction for check cylinder content	20
3.1.6	Functional test	23
4	ORDINARY MAINTENANCE.....	25
5	EXTRA ORDINARY MAINTENANCE.....	25
6	SCHEDULED REVIEW	25

1 Introduction

1.1 Scope and purpose of manual

This manual is a comprehensive guide containing all recommendations necessary to maintenance the Halocarbon HFC125, HFC227EA and HFC23 Gas Extinguishing Systems supplied by Bettati Antincendio srl. The purpose of the maintenance is to check functionality of the system not its effectiveness.

	Safety should be a prime concern during surveillance, inspection review and refilling of Bettati Antincendio gaseous fire extinguishing system and agent containers. All personnel who could be expected to survey, inspect, review, or operate fire extinguishing systems shall be thoroughly trained and kept thoroughly trained in the functions they are expected to perform
	Personnel working in an enclosure protected by a clean agent shall receive training regarding agent safety issues

1.2 Standards and Code of practice

Systems that use extinguishing Halocarbon HFC125, HFC227EA and HFC23 agents are designed according to these standards:

- ✚ UNI EN 15004-1:2008 “Fixed firefighting systems. Gas extinguishing systems. Part 1: Design, installation and maintenance”.
- ✚ UNI EN 15004-4:2008 “Fixed firefighting systems. Gas extinguishing systems. Part 4: Physical Properties And System Design Of Gas Extinguishing Systems For Hfc 125 Extinguishant”.
- ✚ UNI EN 15004-5:2008 “Fixed firefighting systems. Gas extinguishing systems Part 5: Physical properties and system design of gas extinguishing systems for HFC 227ea extinguishant”.
- ✚ UNI EN 15004-6:2008 “Fixed firefighting systems. Gas extinguishing systems - Part 6: Physical properties and system design of gas extinguishing systems for HFC 23 extinguishant”.

Components used in the system that use extinguishing Halocarbon HFC125, HFC227EA and HFC23 agents meet the requirements of the following standards:

- ✚ UNI EN 12094-4:2004 “Fixed firefighting systems. Components for gas extinguishing systems. Requirements and test methods for container valve assemblies and their actuators”.
- ✚ UNI EN 12094-5:2004 “Fixed firefighting systems. Components for gas extinguishing systems. Requirements and test methods for high and low pressure selector valves and their actuators”.
- ✚ UNI EN 12094-6:2006 “Fixed firefighting systems. Components for gas extinguishing systems. Requirements and test methods for non-electrical disable devices”.
- ✚ UNI EN 12094-8:2006 “Fixed firefighting systems. Components for gas extinguishing systems. Requirements and test methods for flexible connectors”.
- ✚ UNI EN 12094-10:2004 “Fixed firefighting systems - Components for gas extinguishing systems . Requirements and test methods for pressure gauges and pressure switches”
- ✚ UNI EN 12094-13:2002 “Fixed firefighting systems. Components for gas extinguishing systems. Requirements and test methods for check valves and non-return valves”.

The maintenance of the gaseous fire-extinguishing system: HFC125, HFC227EA and HFC23 are made according to these standard:

- ✚ UNI EN 15004-1:2008 “Fixed firefighting systems. Gas extinguishing systems. Part 1: Design, installation and maintenance”. Chapter.9
- ✚ UNI 11280 (Italian standard) “preliminary inspection and maintenance of the gaseous fire-extinguishing system. (this standard is more stringent compared to the UNI EN 15004:2008-1 and ISO 14520:2006:1)

1.3 Terms and definitions

For the aim of this manual it's necessary give the following definitions:

Maintenance tag: document that collects and certifies all the maintenance works in conformity with UNI 11280:2008 norm

Cylinder nameplates: document placed on the cylinder that collects the following information: agent extigushant gas type, cylinder data (serial number, operating pressure, weight information: tare, gross and agent), manufacturer data, filling factory data. As well as the nameplate placed on the cylinder body, a compulsory transport label must be placed on the top of the cylinder.

 <small>VIA DISRAELI, 8 42100 REGGIO EMILIA (ITALY) Tel. 0522/369711 Fax 0522/791052 E-mail: info@bettatiantincendio.it</small>			
SISTEMI GAS HALOCARBON Halocarbon Gas System			
CARICATA CON			
Filled with			
PRESSURIZZATA CON	NITROGEN @		bar
Pressurized with			
MATRICOLA/Serial no.			
PRESSIONE DI CARICA @ 22°C			bar
Filling pressure @ 22°C			
CAPACITA'/Capacity			Litre
TARA/Tare			Kg
PESO VALVOLA, PESCANTE E CAPPELLOTTO			Kg
Valve, dip tube and cup weight			
PESO CARICA			Kg
Filling Weight			
PESO LORDO			Kg
Gross Weight			

Cylinder nameplate



Example of a transport label

Maintenance Manual : documents that provides all the necessary manufacturer recommendations to the maintenance and the use of the system.

Ordinary maintenance: maintenance done on site and with common tools. It's called ordinary as the trouble are small and the reparations need common tools and materials.

Extra ordinary maintenance: this type of maintenance can't be done on site and needs specific tools, equipment and involve the replacement of entire parts of the system or even the entire design review.

Surveillance: it is a simple visual inspection to check if all the equipment and the systems are fine, easily accessible and don't show material damages. The surveillance can be done by the user only after a regular formation done by recommended Bettati Antincendio trained technicians on the operation and use the system, in particular regarding safety issues.

Trained technician: is a person who has attended theoretical and practical courses for gaseous fire-extinguishing system in Bettati Antincendio. To that person who has successfully passed the final exam will be given a certificate of assessment for maintenance of Bettati Antincendio gaseous fire-extinguishing system .

Qualified refilling station: organization with the necessary tools and equipment for refilling that he attended a practical and theoretical courses for refilling of Bettati Antincendio gaseous fire-extinguishing system. To that person who has successfully passed the final exam will be given a certificate of assessment for refilling of Bettati Antincendio gaseous fire-extinguishing system

Person in charge of the fire extinguishing system: user or his delegate trained on the operation (surveillance/visual inspection) and use the system in particular regarding safety issues.

User: owner or gas extinguishing fire-fighting system holder.

Working documents: these documents shall be prepared only by persons fully experienced in the design of extinguishing systems. Deviation from these documents shall require permission from the authority.

Working documents shall include the following items:

- a) drawings, to an indicated scale of extinguishant distribution system, including containers, location of containers, piping and nozzles, valves and pressure-reducing devices and pipe hanger spacing;
- b) name of owner and occupant;
- c) location of building in which hazard is located;
- d) location and construction of protected enclosure walls and partitions;
- e) enclosure cross-section, full height or schematic diagram, including raised access floor and suspended ceiling;
- f) type of extinguishant being used;
- g) extinguishing or inerting concentration, design concentration and maximum concentration;
- h) description of occupancies and hazards to be protected against;
- i) specification of containers used, including capacity, storage pressure and mass including extinguishant;
- j) description of nozzle(s) used, including inlet size, orifice port configuration, and orifice size/code and orifice size of pressure-reducing devices, if applicable;
- k) description of pipes, valves and fittings used, including material specifications, grade and pressure rating;
- l) equipment schedule or bill of materials for each piece of equipment or device, showing device name, manufacturer, model or part number, quantity and description;
- m) isometric view of extinguishant distribution system, showing the length and diameter of each pipe segment and node reference numbers relating to the flow calculations;
- n) enclosure pressurization and venting calculations;
- o) description of fire detection, actuation and control systems.

1.4 Service schedule

The user shall arrange a maintenance program according to UNI 11280:2008 standard and with the instructions of this manual.

The service and maintenance schedule shall be carried out under contract by a recommended Bettati Antincendio trained technicians

The good maintaining and the efficiency of the system is a user responsibility, he/she shall provide the:

- 1) Continuous surveillance of the system;
- 2) To make a maintenance contract with a recommended Bettati Antincendio trained technicians.

1.5 Periodicity service schedule

The extinguishing system maintenance is structured in distinct phase, with different periodicity and it shall comply to the following tab. 1.

Phase	Minimum Periodicity according to UNI 11280:2008	Necessary Doc.	Essential operations	Competent person
-------	-------------------------------------------------	----------------	----------------------	------------------

Surveillance	At least monthly	Recording the check list in a proper document	Part. 2	Person in charge of the fire extinguishing system
Periodical inspection	At least every 6 months	Recording the check list in a proper document + report of maintenance	Part. 3	Trained technicians
Ordinary maintenance	Occasional as needed	report of maintenance	Part. 4	Trained technicians
Extra ordinary maintenance	Occasional as needed	report of maintenance	Part. 5	Trained technicians
Planned review	Every 10 years	Recording the check list in a proper document	Part. 6	Qualified refilling station

Tab. 1.1 Periodicity and phase

1.6 System components

The fire-fighting gas extinguishing Halocarbon HFC125, HFC227EA and HFC23 systems can be subdivided in several typologies:

- ↗ Single cylinders
- ↗ Multiple cylinders

Single cylinder, capacity of 14 L and 27L for HFC125 and HFC227ea halocarbon gas:

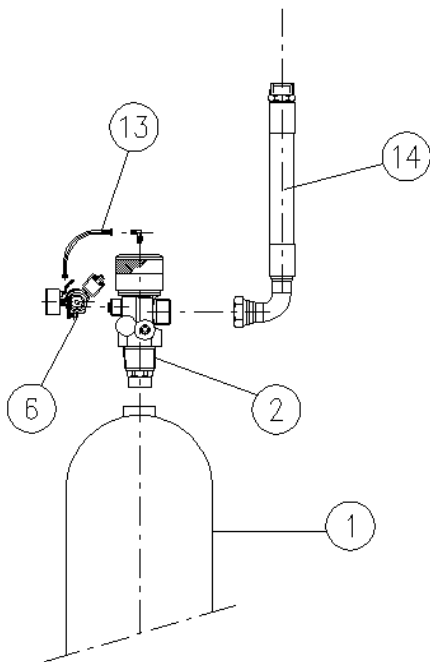

Tab. 1.2 Single cylinder

1	Cylinder filled with halocarbon gas and pressurized by nitrogen at 42 bar
2	Halocarbon gas valve with 3/4" outlet and safety plug
6	BETTATI manual solenoid actuator composed by: solenoid pilot valve 24 Vcc, manual swivel actuator, removable pressure gauge with supervisory pressure switch (N.O.), bleeder valve
13	Pilot Flex hose
14	Discharge flex hose 3/4"

Tab. 1.2 Components list for single cylinder

Single cylinder, capacity of 50 L, 75 L and 120L for HFC125 and HFC227ea halocarbon gas:

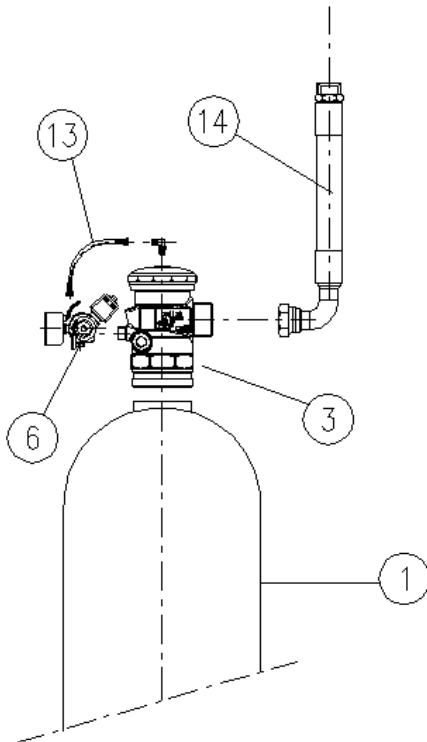

Tab. 1.3 Single cylinder

1	Cylinder filled with halocarbon gas and pressurized by nitrogen at 42 bar
3-4	Halocarbon gas valve 1"1/2 – 2" with outlet and safety plug
6	BETTATI manual solenoid actuator composed by: solenoid pilot valve 24 Vcc, manual swivel actuator, removable pressure gauge with supervisory pressure switch (N.O.), bleeder valve
13	Pilot Flex hose
14	Discharge flex hose 1"1/2 – 2"

Tab. 1.3 Components list for single cylinder

Single cylinder, capacity of 14 L and 27L for HFC23 halocarbon gas:

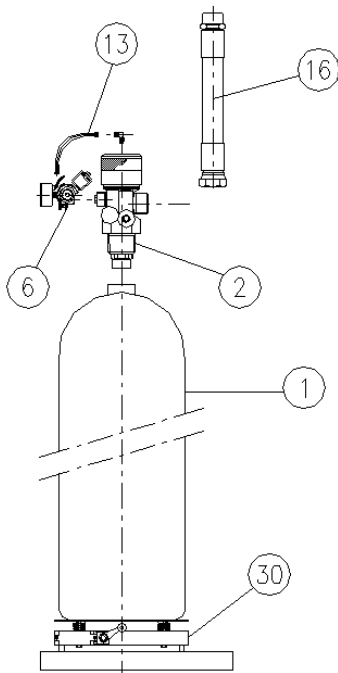

Tab. 1.4 Single cylinder

1	Cylinder filled with halocarbon gas
2	Halocarbon gas valve with 3/4" outlet and safety plug
6	BETTATI manual solenoid actuator composed by: solenoid pilot valve 24 Vcc, manual swivel actuator, removable pressure gauge with supervisory pressure switch (N.O.), bleeder valve
13	Pilot Flex hose
16	Discharge flex hose 3/4"
30	Weight control device

Tab. 1.4 Components list for single cylinder

Single cylinder, capacity of 50 L, 75 L and 120L for HFC23 halocarbon gas:

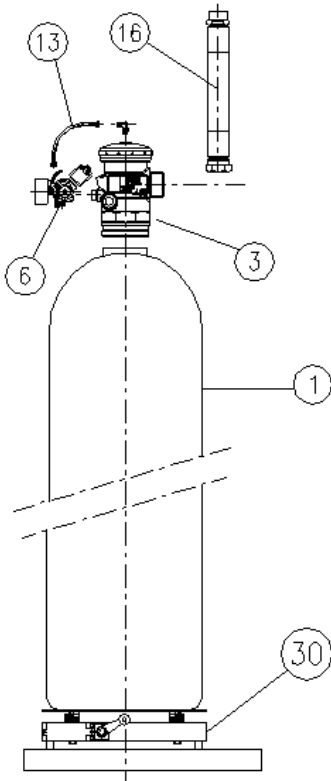

Tab. 1.5 Single cylinder

1	Cylinder filled with halocarbon gas
2	Halocarbon gas valve 1"1/2 – 2" with outlet and safety plug
6	BETTATI manual solenoid actuator composed by: solenoid pilot valve 24 Vcc, manual swivel actuator, removable pressure gauge with supervisory pressure switch (N.O.), bleeder valve
13	Pilot Flex hose
16	Discharge flex hose 1"1/2 - 2"
30	Weight control device

Tab. 1.5 Components list for single cylinder

Multiple cylinders for HFC125 and HFC227ea halocarbon gas

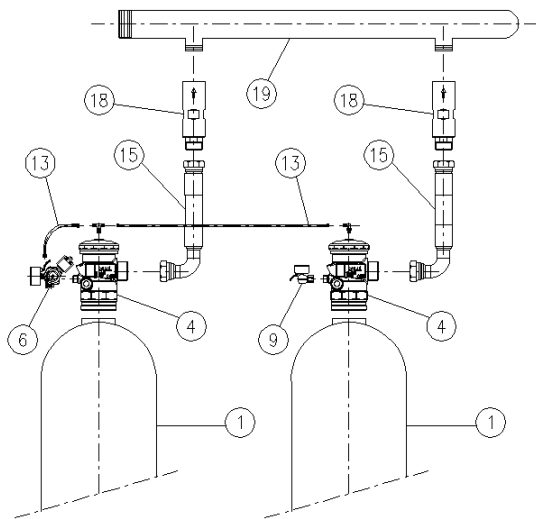

Tab. 1.6 Mul cylinder

1	Cylinder filled with halocarbon gas and pressurized by nitrogen at 42 bar
4	Halocarbon gas valve with 2" outlet and safety plug
6	BETTATI manual solenoid actuator composed by: solenoid pilot valve 24 Vcc, manual swivel actuator, removable pressure gauge with supervisory pressure switch (N.O.), bleeder valve
9	Removable group with electric contacts pressure gauge (N.O.);
13	Pilot Flex hose
15	Discharge flex hose 2"
18	Non-return valve 2";
19	Gas manifold made of steel schedala 40 type

Tab. 1.6 Components list for multiple cylinder

Multiple cylinders for HFC23 halocarbon gas

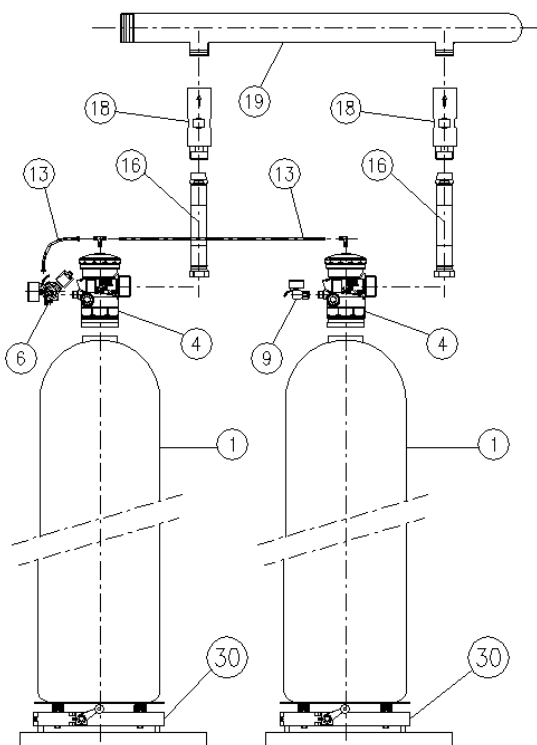

Tab. 1.7 Mul cylinder

1	Cylinder filled with halocarbon gas
4	Halocarbon gas valve with 2" outlet and safety plug
6	BETTATI manual solenoid actuator composed by: solenoid pilot valve 24 Vcc, manual swivel actuator, removable pressure gauge with supervisory pressure switch (N.O.), bleeder valve
9	Removable group with electric contacts pressure gauge (N.O.);
13	Pilot Flex hose
15	Discharge flex hose 2"
18	Non-return valve 2";
19	Gas manifold made of steel schedala 40 type
30	Weight control device

Tab. 1.7 Components list for multiple cylinder

2 System surveillance

It is a simple visual inspection to check if all the equipment and the systems are fine, easily accessible and don't show material damages. The surveillance can be done by the user or by a person delegated only after a regular formation, done by recommended Bettati Antincendio trained technicians, on the operation and use the system, in particular regarding safety issues.

The system surveillance shall be done at least monthly.

	Any fault shall be removed getting through the maintenance company with trained technician
-----------------------------------------------------------------------------------	---------------------------------------------------------------------------------------------------

The system surveillance consists in a preventive measurement that checks the system by one of these verifications:

- Visual check of the gauge:** Check removable pressure gauge of extinguishing cylinders, inert gas shall be within 10% of correct charge pressure indicated on the cylinders label. This data shall be adjusted for the ambient temperature. (see the graphic below).



Fig. 2.1 Pressure gauge

HFC125 pressure/temperature graphic, gas pressurized at 42 bar at 22°C – rif. UNI EN 15004:4

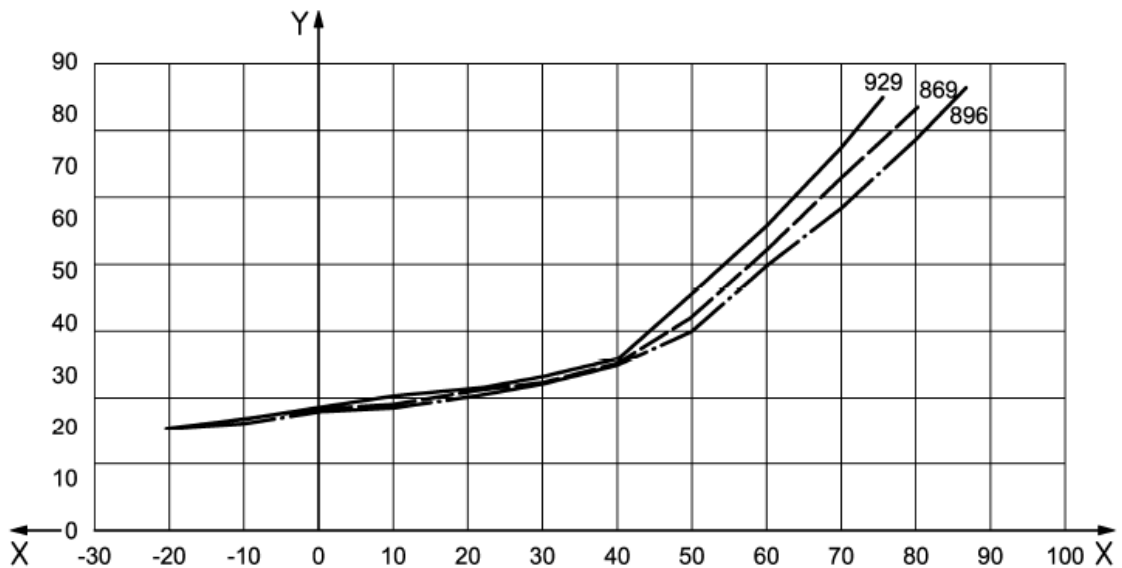

Key

- X temperature, °C
- Y pressure, bar

Below some examples has been collected:

Example n°1:

- Pressure cylinder at 22° = 42 bar (value read on the cylinder nameplate)
- Cylinder storage ambient temperature 0°C

The pressure shown on the pressure gauge should be 18 bar.

Example n°2:

- Pressure cylinder at 22° = 42 bar (value read on the cylinder nameplate)

Cylinder storage ambient temperature 50°C

The pressure shown on the pressure gauge should be 50 bar.

HFC227ea pressure/temperature graphic, gas pressurized at 42 bar at 21°C – rif. UNI EN 15004:4

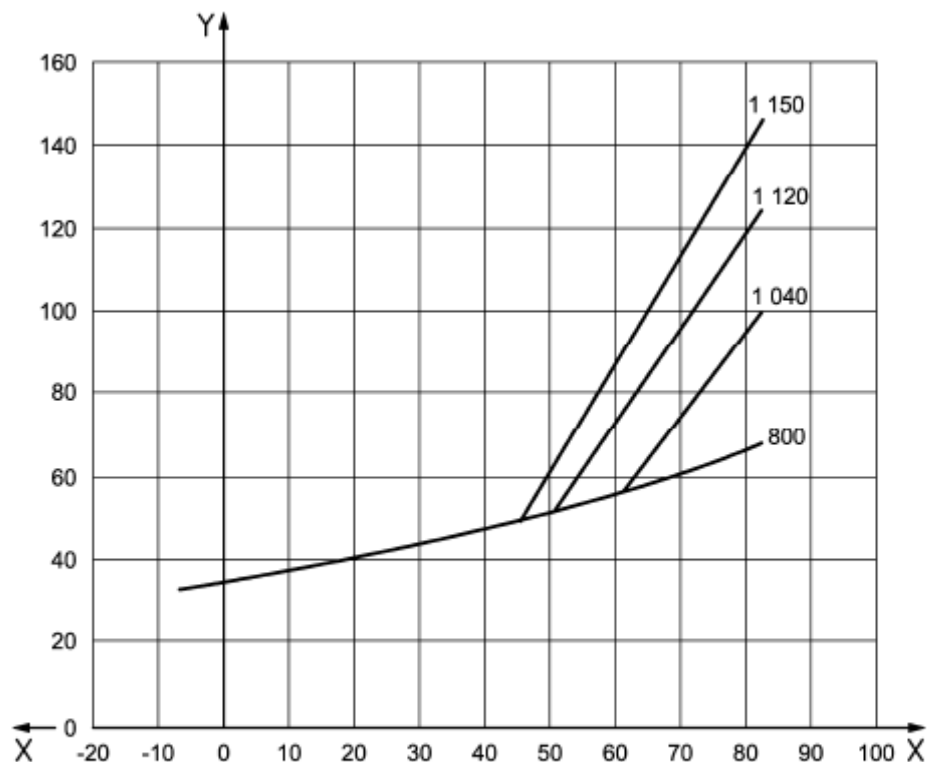

Key

X temperature, °C

Y pressure, bar

Below some examples has been collected:

Example n°1:

- Pressure cylinder at 22° = 42 bar (value read on the cylinder nameplate) with a fill density of 1150 kg/m³
- Cylinder storage ambient temperature 0°C

The pressure shown on the pressure gauge should be 35 bar.

Example n°2:

- Pressure cylinder at 22° = 42 bar (value read on the cylinder nameplate) with a fill density of 1150 kg/m³

Cylinder storage ambient temperature 50°C

The pressure shown on the pressure gauge should be 63 bar.

HFC23 pressure/temperature graphic- rif. UNI EN 15004:6

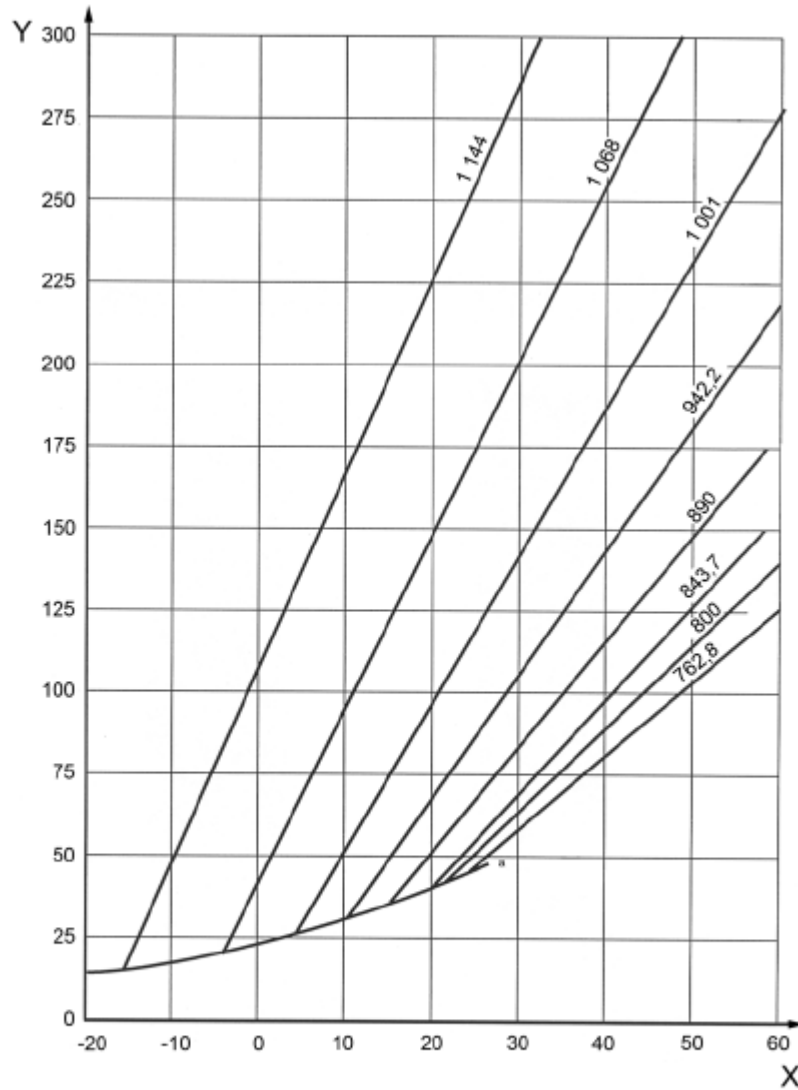

Key
X temperature, °C
Y pressure, bar
^a Critical point

- **Visual check:** on the detection panel of any absence of fault for that system equipped by electrical devices for the low pressure signaling (low pressure switch and removable pressure gauge with supervisory pressure switch);
- **Visual check:** if the safety device placed on the manual actuator is connected and sealed ;
- **Visual check:** of the presence of disease and fault on the extinguishing panel
- **Visual check:** if the maintenance tag is completely filled in every fields:
 - ☑ System's serial number;
 - ☑ Classification , type and system description;
 - ☑ Periodical inspection's expiration date (month/year);
 - ☑ Planned review's expiration date (month/year);
 - ☑ Legible trained technician signature

 <small>VIA DISRAELI, 8 42100 REGGIO EMILIA (ITALY) Tel. 0522/369711 Fax 0522/791052 E-mail: info@bettatiantincendio.it</small>		
Maintenance tag Standard UNI 11280:2008		
SERIAL No		
SYSTEM TYPE		
INERT GAS SYSTEM		
HALOCARBON GAS SYSTEM		
CO2 GAS SYSTEM		
ACTUATION TYPE		
AUTOMATIC		
MANUAL		
Planned review	date	ex.date
Periodical check		
date	expire date	signature

Fig. 2.2 Maintenance tag

 <small>VIA DISRAELI, 8 42100 REGGIO EMILIA (ITALY) Tel. 0522/369711 Fax 0522/791052 E-mail: info@bettatiantincendio.it</small>		
SISTEMI GAS HALOCARBON Halocarbon Gas System		
CARICATA CON Filled with		
PRESSURIZZATA CON Pressurized with	NITROGEN @	bar
MATRICOLA/Serial no.		
PRESSIONE DI CARICA @ 22°C Filling pressure @ 22°C		bar
CAPACITA'/Capacity		Litre
TARA/Tare		Kg
PESO VALVOLA, PESCANTE E CAPPELLOTTA Valve, dip tube and cup weight		Kg
PESO CARICA Filling Weight		Kg
PESO LORDO Gross Weight		Kg

Fig. 2.3 Cylinder label

- **Visual check:** if cylinder's label is applied on the cylinder and completely and correctly filled.

- **Visual check:** if there aren't any fault such as obstructed nozzles, leaks, corrosions, flex hose disconnections or cracks, etc and that all mechanical device are accessible;

- **Visual check:** if all the pipe supports, brackets, cylinder supports showing corrosion or mechanical damage;

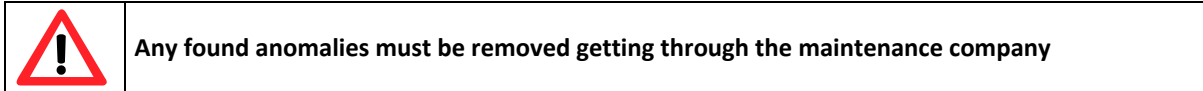

3 System control

The system inspection consists in a thoroughly maintenance that checks the correct and complete system functionality. The user should keep all the working documents that shall be shared with the trained technician.

The check DO NOT verifies the system design but only the correct system functionality.

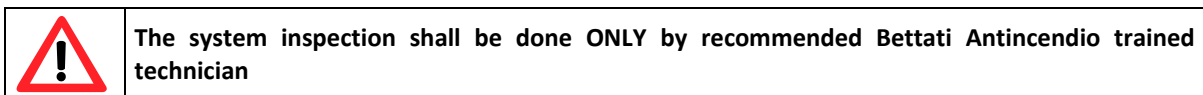

The system inspection shall be done every 6 month in conformity with UNI 11280 (Italian standard) “preliminary inspection and maintenance of the gaseous fire-extinguishing system. *(this standard is more stringent compared to the UNI EN 15004:2008-1 and ISO 14520:2006:1)*

The found anomalies must be removed, otherwise the system must be stated NOT working, and the reason shall be communicated to the user by a maintenance minutes.

It must be used only standard components and Bettati Antincendio’s products.

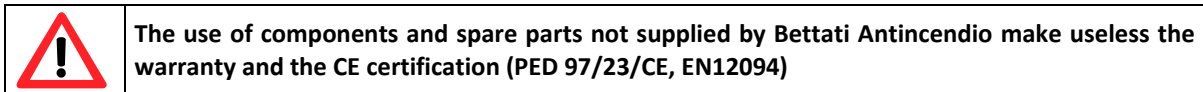



A **fac-simile** form used during a periodical inspection is shown below. In the form are listed all the compulsory operation which they shall be done.

CHECKING ACTIVITIES	ESITO		
	P	N	N.A.
DETECTION SYSTEM			
Check if the control panel and the detection system comply to the original design			
Check if the manual activation devices are immediately usable and accessible without barriers			
Check the connection with the remote alarm station (it shall be notified that you are doing an inspection)			
Check the correct operation of each detector by using appropriate equipment			
Detector cleaning (>25% for each zone in the case of analog detectors, 100% in the case of conventional detectors)			
Check the correct actuation of the alarm on the control panel			
Check the activation of the extinguishing system as described in the pt. 5,4,6			
Check the activation of the visual-acoustic alarm equipment			
Check for presence and proper functioning of the ventilation stop system			
Check the proper functioning of doors, damper and related closing devices			
Check the correct alarm report to the remot control panel			
Check the correct functioning of the manual points by their activation			
Check the good state of all circuits subject to supervision to ensure proper reporting of failure on the control panel			
Check the charge state of the batteries			
Check the correct power supply by means of batteries when the primary supply is switched off			
Inside and outside cleaning of the control panel			
EXTINGUISHING SYSTEM	P	N	N.A.
Check that the enclosure dimensions have not been modified			
Check the enclosure integrity by means of the door fan integrity test			
Check the proper functioning of doors, damper and related closing devices (if present)			
Make sure the windows are not open or equipped with automatic closing devices			
Check the switch off of the air-conditioning system at the extinguishing system activation			
Check that the current state of the system conforms to the original project			
Visual inspection of the state of the pipes, fittings, nozzles			
Visual inspection of the state of the installation (fixation, stability, corrosion and damage) of the pipes and fittings			
Check that the nozzles are free of obstructions or obstructed by materials which can reduce the proper distribution of gas			
Check the conformity to the original design of the number, capacity and type of extinguishing agent			
Check the correct installation of the cylinders and of the manifold (fixation, stability, corrosion and damage)			
Make sure the temperature in the storage cylinder local is within the limits specified in the manufacturer's manual			
Check the pressure storage (adjusted for temperature) shall be within 10% of the working pressure			
Check the expiration date of the planned review (cylinder test)			
Functional test for automatic extinguishing gas system			
Functional test for manual extinguishing gas system			

Tab. 3.1 Checking activities

3.1 Essential operations for the extinguishment system control

	Any fault shall be removed getting through the maintenance company with trained technician
	These procedures shall be done ONLY by recommended Bettati Antincendio trained technician
	The use of components and spare parts not supplied by Bettati Antincendio make useless the warranty and the CE certification (PED 97/23/CE, EN12094)

3.1.1 Minimum tools for maintenance

- 1) Digital removable pressure gauge with swivel nut Bettati Mod dV-2 (calibrated device);
- 2) Leak detection liquid (water –bath);
- 3) Lubricant (grease)
- 4) General spare parts supplied by Bettati Antincendio;
- 5) Generic tools: screwdriver, spanner (22), etc.
- 6) Machine for door fan integrity test (fig. 3.3)



Fig. 3.2 Digital pressure gauge with swivel nut Bettati Mod dV-2

3.1.2 Enclosure every 12 months

- At least every 12 months carry out a check of enclosure integrity using the machine door fan integrity test (fig. 3.3). If the measured aggregate area of leakage has increased from that measured during installation which would adversely affect system performance, carry out work to reduce the leakage.
- Check that doors, windows and even air conditioning systems (such as extractor fan) are not open or that they are equipped with automatic closing systems.

In case of malfunctioning of the automatic closing systems, it is necessary to consider immediate corrective actions.



Fig. 3.3 Machine for Door fan test

3.1.3 Pipeline and nozzles

- Check that the system is in conformity with the original design

In case that these changes are ascertained it is necessary redesign the entire extinguishing system or restore it.

- Check visually the pipeline, fittings and nozzles state

In case that corrosion phenomena on the pipes, fittings and nozzles are ascertained it is necessary restore the initial conditions.

- Check that the discharge nozzles are not obstructed with materials that can reduce the correct gas discharge

In case that a reduction of a gas discharge is ascertained it is necessary restore the initial conditions.

3.1.4 Cylinder bank

- Check if the number, the capacity and the gas extinguishing type of the cylinders match with the original design

In case that some changes are ascertained, it is necessary restore the original conditions.

- Check the correct cylinders installation

In case that installation changes are ascertained, it is necessary restore the original conditions.

- Asking to the person in charge of the fire extinguishing system if the storage cylinders space temperature is maintained within the design limits of the Bettati Antincendio components (-20° + 50° C)

- Check the testing date stamp on the cylinders

In case that the testing date has expired (usually 10 years) proceed with the procedure described in paragraph 6.

- Check the cylinder content: the removable pressure gauge of extinguishing cylinders, inert gas shall be within 10% of correct charge pressure indicated on the cylinders label. This data shall be adjusted for the ambient temperature (see pag. 10 ÷ pag. 13).

The cylinder removable pressure gauge shall be compared to a separate digital removable pressure gauge Bettati Mod dV-2 at least annually.

3.1.5 Operating instruction for check cylinder content

1. Unscrew the swivel nut with the help of the spanner (22) (fig 3.5)



Fig. 3.5 Swivel nut pressure connection

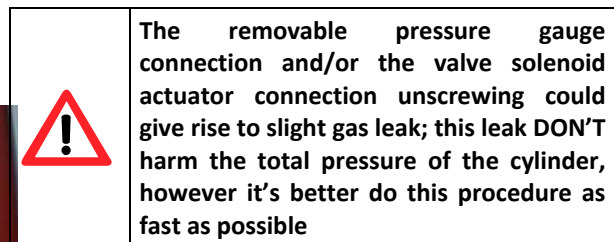

2. Screw by hand the digital removable pressure gauge Bettati Mod. dV-2 until the pressure is read on the display.

If an inert gas container shows a loss in pressure (adjusted for temperature) of more than 10% it shall be refilled according to the procedure described on the "Installation manual" (supplied by Bettati Antincendio srl.) and send it to Bettati Antincendio or a qualified refilling station.

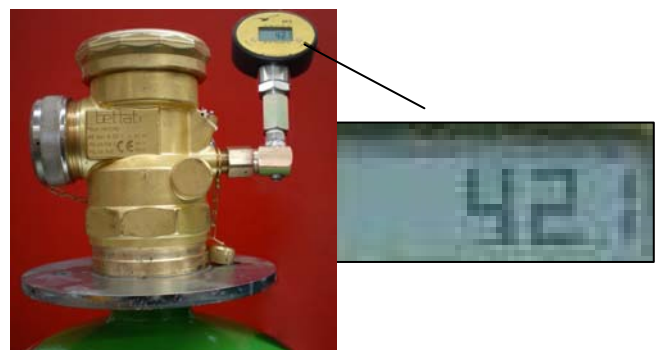

Fig. 3.6 Digital pressure gauge Bettati Mod. dV2

3. Unscrew by hand the digital removable pressure gauge Bettati Mod. dV-2.

4. Put the grease on the valve pressure connection (fig. 3.7)



Fig. 3.7 Grease

5. Before replacing the removable gauge group and/or the removable valve solenoid/manual actuator visually verify that the o-ring or washer metal is present and not damaged (see fig. 3.8 – 3.9 – 3.10 – 3.11)
If the O-ring or washer metal are not present you must put it back



Fig. 3.8 o-ring in the removable gauge group



Fig. 3.9 washer metal in the removable gauge group



Fig. 3.10 o-ring in the removable valve solenoid/manual actuator



Fig. 3.11 washer metal in the removable valve solenoid/manual actuator

6. Tighten the gauge group removable and or the removable valve solenoid/manual actuator up to the edge of the nut, orient the gauge to the desired position, tighten the nut rotating spanner 22 to lock the group.

7. Check with the leak detection liquid (eg soap water) the absence of losses in the points indicated in the photos below: removable valve solenoid/manual actuator

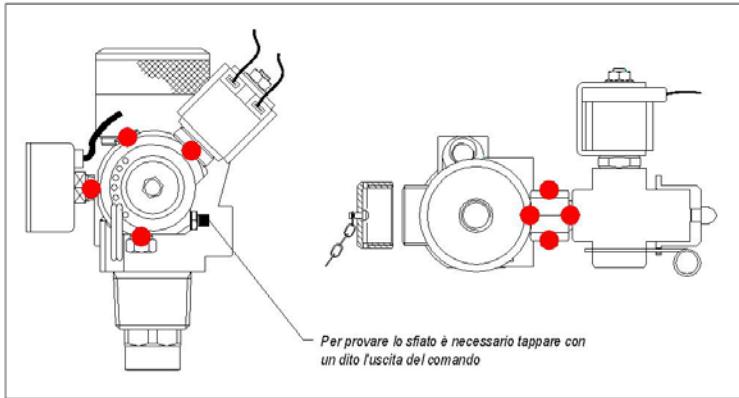

8. Check with the leak detection liquid (eg soap water) the absence of losses in the points indicated in the photos below: pressure gauge group removable

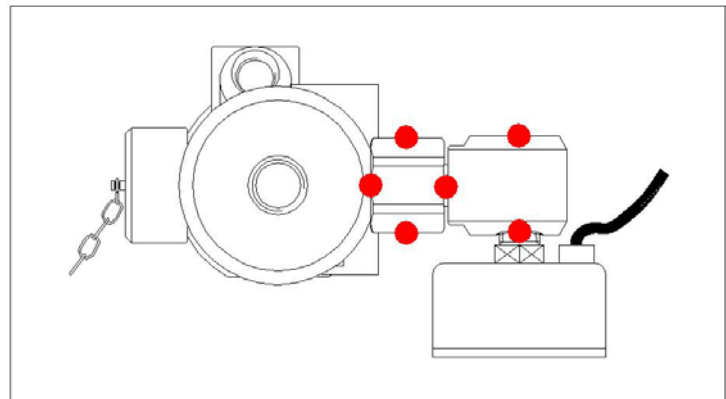

Where losses are found will be necessary to send the entire component to Bettati Antincendio that will repair and/or replacement the component



In case that it is necessary to leave the pressure connection for a long time it is necessary to screw the pressure connection protection cup, getting sure with the leak detection liquid that there are not gas leaks.

Without the cap outlet pressure cylinder loses pressure.

3.1.6 Functional test

🔧 Check the removable valve solenoid/manual state without discharge the extinguishing gas.
In case of unsuccessful tests, it is necessary to consider immediate corrective actions.

- 🔧 Unscrew nut M10 and dismount the solenoid valve placed on the actuator group see the picture s below

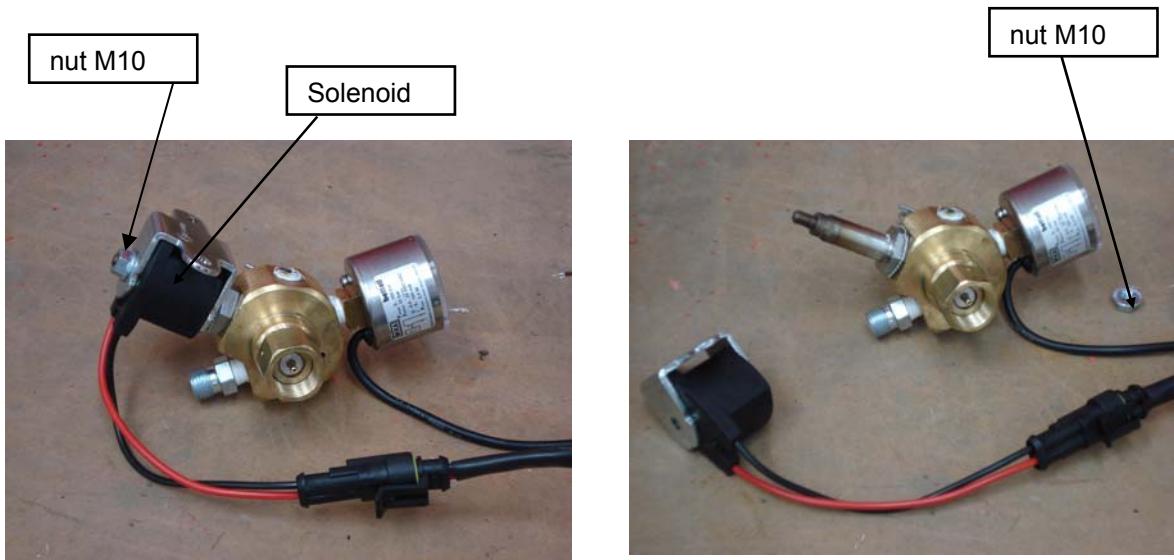

- 🔧 Insert a metallic body (e.g. screwdriver) inside the coil and activate the discharge button (placed on the detector panel and /or the remote one) checking the coil excitement. Once that the coil will be activated, the metallic body should be attracted by the magnetic field.

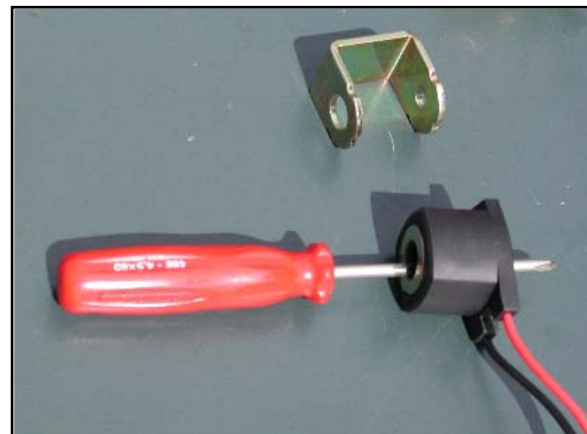

- 🔧 Before restoring the system initial conditions (reconnecting the coil) check the absence of the magnetic field generated previously by the coil, subsequently restore the initial conditions

SECOND METHOD

With this method we simulate the actual actuation of the solenoid assembly

	<p>This test shall be done ONLY by recommended Bettati Antincendio trained technician</p>
--	--------------------------------------------------------------------------------------------------

	<p>This test must be done only for cylinder with a capacity of 50,75 or 120 L</p>
--	------------------------------------------------------------------------------------------

	<p>This test must NOT be done for cylinder with a capacity of 14 and 27 L</p>
--	--------------------------------------------------------------------------------------

1. Remove the safety pin (1)
2. Screw the screw for open/close pressure connection (2) in order to isolate the solenoid and to not permit at the gas to flow out;
3. Disconnect the pilot flex hose (3) from the head of the valve (5);
4. Activate the coil of the solenoid actuator (4) connecting the wires red/black to the battery poles or activating the detection panel;
5. Check if the solenoid works correctly permitting the gas flowing in the flex hose;
6. Reconnect the flex hose (3) in the valve head;
7. Check if there are any leakages in the connection of the solenoid;
8. Unscrew the screw for open/close pressure connection (2) in order to restore the initial state;
9. Restore the safety pin (1) and reconnect the pilot flex hose (3) to the elbow (5);
10. Check if there are any leakages in the connection of the solenoid as shown in figure.

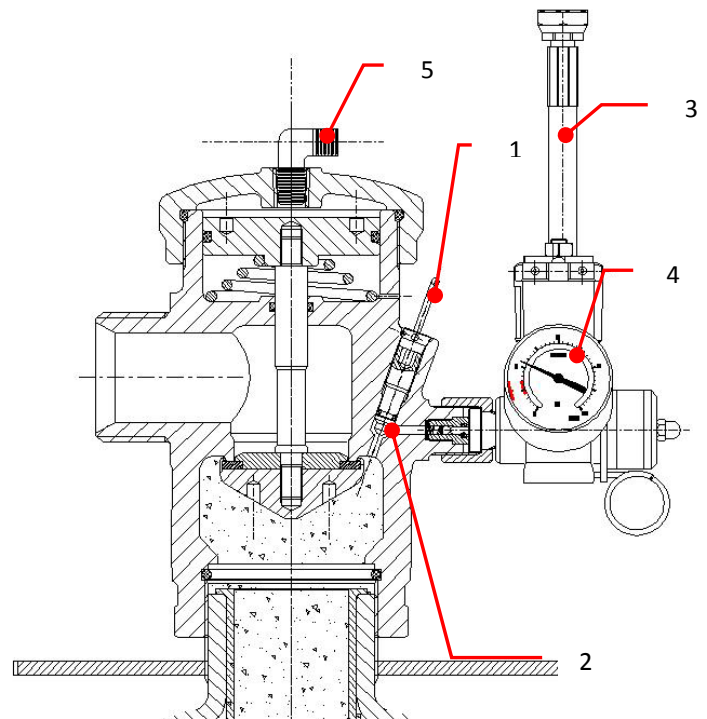

Figure 5.5 Blank test, system description

To test the bleeder valve rotate the actuator up side down and close the actuator outlet, use a leak detector to check if there are any leakages in the bleeder valve (6).

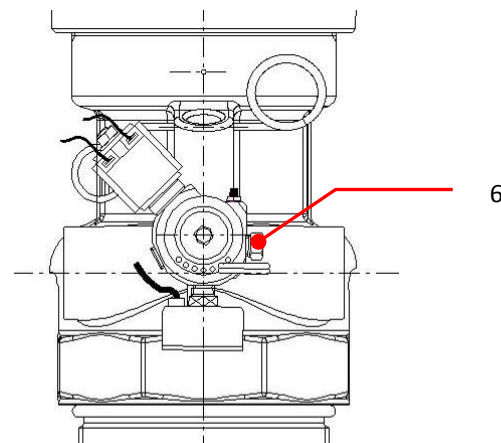



Figure 5.6 Blank test, bleeder valve test

4 Ordinary maintenance

	Any fault shall be removed getting through the maintenance company with trained technician
-----------------------------------------------------------------------------------	--------------------------------------------------------------------------------------------

	The ordinary maintenance shall be done ONLY by recommended Bettati Antincendio trained technician
-----------------------------------------------------------------------------------	----------------------------------------------------------------------------------------------------------

Ordinary maintenance: maintenance done on site and with common tools. It's called ordinary as the trouble are small and the reparations need common tools and materials.

The ordinary maintenance is an ongoing operation and it lasts for all the plant life.

During it the trained technician shall do all those operations that guarantee the system functioning.

During these operation could come visible some problems solvable by the replacement of some parts and/or system components.

	The use of components and spare parts not supplied by Bettati Antincendio make useless the warranty and the CE certification (PED 97/23/CE, EN12094)
-----------------------------------------------------------------------------------	------------------------------------------------------------------------------------------------------------------------------------------------------

All the reparation must be done immediately. If it doesn't happen the technician must declare the system not working and inform the user explaining to him the causes.

5 Extra ordinary maintenance

	Any fault shall be removed getting through the maintenance company with trained technician
-------------------------------------------------------------------------------------	--------------------------------------------------------------------------------------------

	The extraordinary maintenance shall be done ONLY by recommended Bettati Antincendio trained technician
-------------------------------------------------------------------------------------	---------------------------------------------------------------------------------------------------------------

Extra ordinary maintenance: this type of maintenance can't be done on site and needs specific tools, equipment and involve the replacement of entire parts of the system or even the entire design review.

During the Extra ordinary maintenance the enclosure can be modify, expanded and transformed.

In this case a new design must be edited, the owner must give and predispose it to the maintenance man before carry out the modifications.



	The use of components and spare parts not supplied by Bettati Antincendio make useless the warranty and the CE certification (PED 97/23/CE, EN12094)
-------------------------------------------------------------------------------------	------------------------------------------------------------------------------------------------------------------------------------------------------







6 Scheduled review

	Any fault shall be removed getting through the maintenance company with trained technician
-------------------------------------------------------------------------------------	--------------------------------------------------------------------------------------------

	The scheduled review shall be done ONLY by recommended Bettati Antincendio qualified filling station
-----------------------------------------------------------------------------------	-------------------------------------------------------------------------------------------------------------

	The use of components and spare parts not supplied by Bettati Antincendio make useless the warranty and the CE certification (PED 97/23/CE, EN12094)
-----------------------------------------------------------------------------------	-------------------------------------------------------------------------------------------------------------------------------------------------------------

-  Necessary operation in order to maintain efficiently the extinguishing system every 10 years.
-  All the compulsory checking expected during the surveillance and the Inspection shall be done.

-  The extinguishing agent shall be replaced.
-  Cylinder testing applying 1.5 times the working pressure, inclusive of the internal assessment of the cylinder .
-  Replacement or valve review: assessment and functional checking of the entire valve, gas flow areas checking, safety device replacement against the overpressure and seals.
-  Hoses and non-return valves hydraulic testing at 1.5 times the working pressure and their replacement in case of failure
-  Functional checking and legibility of the removable pressure gauge with a calibrated and certified one
-  Door fan integrity test to test the ambient leak-tightness.

